

**CITY OF WILLISTON, FLORIDA
CITY COUNCIL MEETING
AGENDA**

DATE: WEDNESDAY, NOVEMBER 04, 2020
TIME: 6:00 P.M.
PLACE: WILLISTON CITY COUNCIL CHAMBER

CALL TO ORDER

ROLL CALL

MEMBERS:

Mayor Jerry Robinson
Council President Justin Head
Vice-President Marguerite Robinson
Vacant
Councilmember Debra Jones
Councilmember Elihu Ross

OTHERS:

City Manager Jackie Gorman
City Attorney Fred Koberlein
City Clerk Latricia Wright
Deputy City Manager CJ Zimoski

OPENING PRAYER AND PLEDGE OF ALLEGIANCE TO THE FLAG

ITEM – 1 – ADDITIONS, DELETIONS, CHANGES AND APPROVAL OF THE AGENDA

ITEM – 2 – PUBLIC PARTICIPATION

ITEM – 3 – CONSENT AGENDA

- Council minutes from October 22, 2020 (pp4-7)
- Resolution 2020-68: A Resolution of the City Council of the City of Williston, Florida, Authorizing the Purchase of a Thompson 6” Water Pump as Budgeted in the 2020/2021 CIP Equipment Purchase Program. (pp8-16)
- Resolution 2020-72: a Resolution of the City Council of the City of Williston, Florida approving a proposed final subdivision plat for Cottage Cove North, Phase 3. (pp17-19)
- Resolution 2020-73: a Resolution of the City Council of the City of Williston, Florida, granting with appropriate conditions and safeguards, a Special Exception per Ordinance No. 673 of the City of Williston Code of Ordinances; providing for a Special Exception to the permitted use within residential zoning to allow horses for non-commercial purposes on parcels of three (3) acres or more (but less than eight (8) acres within the corporate limits of the City of Williston, Florida; and providing an effective date.(pp20-22)

ITEM – 4 – OLD BUSINESS

A. STAFF AND BOARD AND COUNCILOR UPDATES

- CITY MANAGER JACKIE GORMAN
- DEPUTY CITY MANAGER CJ ZIMOSKI

CITY OF WILLISTON, FLORIDA
CITY COUNCIL MEETING

ITEM – 5 – NEW BUSINESS –

- A. DISCUSSION WITH POSSIBLE ACTION: PARK HOUR WAIVER- DEPUTY CITY MANAGER CJ ZIMOSKI (pp23)
- B. DISCUSSION WITH POSSIBLE ACTION: REQUEST FOR EXTENSION ON LIEN REDUCTION FOR PROPERTY LOCATED AT 415 SE 4TH DR., CAROL CHICO (FORMERLY OWNED BY FALISI) - CITY MANAGER JACKIE GORMAN.(pp24-27)
- C. RESOLUTION 2020-69: A RESOLUTION OF THE CITY COUNCIL OF THE CITY OF WILLISTON, FLORIDA, APPROVING THE 2021 GENERAL MUNICIPAL ELECTION DATES AND PROCESS AND ESTABLISHING AN EFFECTIVE DATE.- CITY MANAGER JACKIE GORMAN. (pp 28-30)
- D. RESOLUTION 2020-70: A RESOLUTION OF THE CITY COUNCIL OF THE CITY OF WILLISTON, FLORIDA APPOINTING THE CANVASSING BOARD FOR THE 2021 GENERAL MUNICIPAL ELECTIONS AND ESTABLISHING AN EFFECTIVE DATE.- CITY MANAGER JACKIE GORMAN.(pp 31-36)
- E. CONTINUING ECONOMIC DEVELOPMENT SERVICES-CITY MANAGER JACKIE GORMAN. (pp 34-36)

ITEM – 6 – PUBLIC PARTICIPATION

ITEM – 7 – ANNOUNCEMENTS

ITEM – 8 – ADJOURNMENT

NEXT SCHEDULED MEETING NOVEMBER 17, 2020 AT 6:00 P.M.

Please join my meeting from your computer, tablet or smartphone.

<https://www.gotomeet.me/CityOfWillistonFL>

You can also dial in using your phone.
(For supported devices, tap a one-touch number below to join instantly.)

United States: +1 (646) 749-3122
- One-touch: <tel:+16467493122.645230685#>

Access Code: 645-230-685

YouTube Link: <https://www.youtube.com/channel/UCKtI468kcNjBS2AYgOaBsRQ>

Clicking this link will enable you to see and hear the Council meeting.

**** Because this meeting is being held in person, Florida law requires that it be open to the physical presence of the public. To maintain proper health precautions, we will maintain 6' separations in the**

CITY OF WILLISTON, FLORIDA
CITY COUNCIL MEETING

meeting room and we will offer additional seating in another area for the overflow if needed. Also, we encourage the use of face masks in the meeting room. (Limitation of 50 people)

We invite you to continue participating in our council meetings via telephone or the Internet as we have been doing for the last several weeks. **

Minutes of the City Council meeting may be obtained from the City Clerk's office. The minutes are recorded, but not transcribed verbatim. Persons requiring a verbatim transcript may make arrangements with the City Clerk to duplicate the recordings, or arrange to have a court reporter present at the meeting. The cost of duplication and/or court reporter will be borne by the requesting party.

In accordance with Section 286.0105, Florida Statutes, notice is given that if a person wishes to appeal a decision made by the City Council with respect to any matter considered at this meeting they will need a record of the proceedings, and for such purpose may need to ensure that a verbatim record of the proceeding is made, which record includes the testimony and evidence upon which the appeal is based.

In accordance with Section 286.26, Florida Statutes, persons with disabilities needing special accommodations to participate in this meeting should contact the Mayor through the City Clerk's office no later than 5:00 P.M. on the day prior to the meeting.

**CITY OF WILLISTON, FLORIDA
CITY COUNCIL MEETING
MINUTES**

DATE: TUESDAY, OCTOBER 20, 2020
TIME: 6:00 P.M.
PLACE: WILLISTON CITY COUNCIL CHAMBER

CALL TO ORDER

ROLL CALL

MEMBERS:

Mayor Jerry Robinson
Council President Justin Head
Vice-President Marguerite Robinson
Councilmember Charles Goodman
Councilmember Debra Jones
Councilmember Elihu Ross

OTHERS:

City Manager Jackie Gorman
City Attorney Fred Koberlein
City Clerk Latricia Wright
Deputy City Manager CJ Zimoski

OPENING PRAYER AND PLEDGE OF ALLEGIANCE TO THE FLAG

Opening prayer and Pledge of Allegiance to the flag was led by Mayor Robinson.

ITEM – 1 – ADDITIONS, DELETIONS, CHANGES AND APPROVAL OF THE AGENDA

Councilmember Jones moved to accept agenda as written. Vice-President Robinson seconded. Motion carried by say “Aye” 5-0.

ITEM – 2 – PUBLIC PARTICIPATION

Resident Kellie McCormick, Christine Ziegenfuss and Joab Penney addressed the Council about speeding on NW 1st Ave. Kellie McCormick stated last week her dog was hit by a speeding car and she has complained numerous times to the Police Department and nothing has been done about it. Christine told the Council that people don’t even stop at the stop sign at the intersection of NW 1st Ave and NW 4th St. Joab Penney said he has also complained about people running the stop sign. Kellie McCormick suggested that maybe the City could speed bumps down or anything to help with people speeding on NW 1st Ave. Chief Strow told the Council he has had several Officers monitor the area and they reported back that no one were caught speeding in that area. Deputy Chief Bovaird told Council he would speak with the three residents to see what help he could offer.

ITEM – 3 – CONSENT AGENDA

- Council minutes from October 6, 2020 – Councilmember Jones moved to approve minutes as written. Vice-President Robinson seconded. Motion carried by saying “Aye” 5-0.

ITEM – 4 – OLD BUSINESS

A. STAFF AND BOARD AND COUNCILOR UPDATES

CITY OF WILLISTON, FLORIDA
CITY COUNCIL MEETING

- CITY MANAGER JACKIE GORMAN – City Manager Gorman stated she had nothing to discuss at this time and thanked the Council for allowing her to get her feet wet and everything is going great!
- DEPUTY CITY MANAGER CJ ZIMOSKI – Deputy City Manager Zimoski told the Council that they have started work on the Popeye’s restaurant and they City and the company are working on an agreement for water and sewer.
- CHIEF DENNIS STROW – Chief Strow introduced the newest officer to the Police Department Officer Owen Confessore. Officer Confessore thanked Chief Strow and Deputy Chief Bovaird for bringing him onboard to work for Williston and he’s happy to be working for the City.
- CRA- NICK WILLIAMS – Mr. Williams discussed with the Council a couple of the things the CRA has planned and one of those items is pressure washing the area after they receive permission from the business owners and they have ordered new banners to be placed on the twenty-two (22) new light poles throughout the CRA district.
- PLANNING AND ZONING – ALBERT FULLER –absent

ITEM – 5 – NEW BUSINESS

- A. SPECIAL EXCEPTION SE 2020-03: APPLICATION BY MARC & MELANIE NUSSEL, TO ALLOW HORSES FOR NONCOMMERCIAL PURPOSES ON PARCELS OF 3 ACRES OR MORE IN ACCORDANCE WITH ARTICLE VI- RESIDENTIAL SINGLE-FAMILY DISTRICT; SECTION 60-213 OF THE CITY OF WILLISTON LAND DEVELOPMENT CODE-CITY MANAGER JACKIE GORMAN
City Manager Gorman presented Special Exception 2020-03 to the Council. City Manager Gorman discussed with the Council that the Special Exception to allow horses for noncommercial purposes had been approved by the Planning and Zoning Commission and she’s bringing it before the Council for final approval. Councilmember Ross asked was the applicant in compliance with everything that was required. City Manager Gorman said yes. City Manager Gorman told the Council the only thing missing from the package is the Resolution and she will have that at the next meeting. With no future discussion Councilmember Ross moved to approve Special Exception 2020-03. Councilmember Jones seconded. Motion carried by saying “Aye” 5-0.
- B. COTTAGE COVE NORTH, PHASE 3 – FINAL SUBDIVISION PLAT-CITY MANAGER JACKIE GORMAN –
City Manager Gorman presented Cottage Cove North Phase 3 Final Subdivision plat to the Council, which falls under the description for a Minor Subdivision. City Manager Gorman stated that Cottage Cove North Phase 3, consist of 4 lots and all meet the minimum size requirement for an R-2 zoning district. Easements have been put in place

CITY OF WILLISTON, FLORIDA
CITY COUNCIL MEETING

on the plat to accommodate Electric Utilities, all other are private. The Final Subdivision plat went before the Planning and Zoning Commission on October 5, 2020 and was approved. Councilmember Jones had some concerns about the statement made by City Manager Gorman on utilities being private. City Manager Gorman explained it refers to the water and sewer lines being installed up to the owner's property line and whatever utilities that are on the property are private. After some discussion Vice-President Robinson moved to approve Final Subdivision Plat, Phase 3. Councilmember Jones seconded. Motion carried by saying "Aye" 5-0.

C. RESOLUTION 2020-67: A RESOLUTION OF THE CITY COUNCIL OF THE CITY OF WILLISTON, FLORIDA AMENDING THE PURCHASE PRICE IN RESOLUTION 2020-19, AUTHORIZING THE PURCHASE OF TWO (2) POLICE VEHICLES WITH THE ASSISTANCE OF THE UNITED STATES DEPARTMENT OF AGRICULTURE ("USDA") GRANT. CHIEF STROW

Chief Strow discussed with the Council this item was approved in the Capital Improvement Plan and he's bringing it back to Council because the price of the vehicles changed to \$91,407.00 which the USDA is paying \$64,600.00 and the City will only pay \$26,807.00 for the purchase of two cars fully equipped. With no discussion, Councilmember Jones moved to approve Resolution 2020-67. Vice-President Robinson seconded. Motion carried by saying "Aye" 5-0.

ITEM – 6 – PUBLIC PARTICIPATION

None

ITEM – 7 – ANNOUNCEMENTS

Councilmember Goodman told the Council and the public that he was thankful to have been on the Council and after careful consideration he has decided to resign from the City Council. Councilmember Goodman discussed with the Council the differences he has had with Mayor Robinson and said it would be best if he resigned because he no longer has the passion he had before as a Council member. Councilmember Goodman told the Council he resigned as of this minute and turned over his key card and City computer to Council President Head and walked out. Council President Head asked where there anymore announcements. Mayor Robinson informed everyone that Veteran's Day will be held on Wednesday November 11, 2020 at 11:00 a.m. at Heritage Park Pavilion. Mayor Robinson stated in the past several months there have been those that have called for his resignation as Mayor and a lot of those people are not residents of Levy County or Williston, and after a lot of deliberation on his part, he has reached a decision which is, he will not under any circumstances resign as Mayor of the City of Williston, Florida. Fire Chief Stegall told the Council he and Human Resource Director Brooke Williston meet with the Levy County Fire Chief and the Battalion Chief on coverage for Station 11 in Morriston and they still have issue they need to working out, just wanted to keep the Council posted on what's going on and should have an update before December.

ITEM – 8 – ADJOURNMENT

Vice-President Robinson moved to adjourn meeting at 6:45 p.m. Councilmember Jones seconded. Motion carried by saying "Aye" 4-0.

CITY OF WILLISTON, FLORIDA
CITY COUNCIL MEETING

Please join my meeting from your computer, tablet or smartphone.

<https://www.gotomeet.me/CityOfWillistonFL>

You can also dial in using your phone.
(For supported devices, tap a one-touch number below to join instantly.)

United States: +1 (646) 749-3122
- One-touch: <tel:+16467493122,,645230685#>

Access Code: 645-230-685

YouTube Link: <https://www.youtube.com/channel/UCKt1468kcNjBS2AYgOaBsRQ>

Clicking this link will enable you to see and hear the Council meeting.

**** Because this meeting is being held in person, Florida law requires that it be open to the physical presence of the public. To maintain proper health precautions, we will maintain 6' separations in the meeting room and we will offer additional seating in another area for the overflow if needed. Also, we encourage the use of face masks in the meeting room. (Limitation of 50 people)**

We invite you to continue participating in our council meetings via telephone or the Internet as we have been doing for the last several weeks. **

Minutes of the City Council meeting may be obtained from the City Clerk's office. The minutes are recorded, but not transcribed verbatim. Persons requiring a verbatim transcript may make arrangements with the City Clerk to duplicate the recordings, or arrange to have a court reporter present at the meeting. The cost of duplication and/or court reporter will be borne by the requesting party.

In accordance with Section 286.0105, Florida Statutes, notice is given that if a person wishes to appeal a decision made by the City Council with respect to any matter considered at this meeting they will need a record of the proceedings, and for such purpose may need to ensure that a verbatim record of the proceeding is made, which record includes the testimony and evidence upon which the appeal is based.

In accordance with Section 286.26, Florida Statutes, persons with disabilities needing special accommodations to participate in this meeting should contact the Mayor through the City Clerk's office no later than 5:00 P.M. on the day prior to the meeting.

Date: 11/04/2020

COUNCIL AGENDA ITEM

DISCUSSION: Approve the purchase of a 6" water pump.

REQUESTED BY: CJ Zimoski

PREPARED BY: CJ Zimoski

BACKGROUND / DESCRIPTION: Staff is requesting approval for purchasing a 6" water pump budgeted in the 2020/2021 CIP Budget.

LEGAL REVIEW: N/A

FISCAL IMPACTS: \$39,766.00 This is Florida Sheriffs Contract Pricing.

RECOMMENDED ACTION: Staff recommends approval.

ATTACHMENTS:

CONTRACT RESOLUTION MAP

LEASE OTHER DOCUMENTS

CONSULTANT OR PARTY TO ACTION HAS BEEN NOTIFIED

COUNCIL ACTION:

APPROVED

DISAPPROVED

RESOLUTION 2020-68

A RESOLUTION OF THE CITY COUNCIL OF THE CITY OF WILLISTON, FLORIDA, AUTHORIZING THE PURCHASE OF A THOMPSON 6" WATER PUMP AS BUDGETED IN THE 2020/2021 CIP EQUIPMENT PURCHASE PROGRAM

WHEREAS, the City of Williston needs to replace a dewatering pump, and

WHEREAS, the City of Williston has anticipated this need and budgeted accordingly

NOW, THEREFORE, BE IT RESOLVED by the City Council of the City of Williston, Florida, as follows:

SECTION 1. The above recitals are true and accurate and are made a part of this resolution.

SECTION 2. That the City of Williston hereby authorizes the purchase of a Thompson 6" dewatering pump in the amount of \$39,766.00.

SECTION 3. That the President of the City Council and City Manager are authorized to sign the required Purchase Order.

SECTION 4. This resolution shall become effective immediately upon adoption.

PASSED AND ADOPTED at a meeting of the City Council this 4th day of November, 2020.

CITY OF WILLISTON, FLORIDA

Justin Head, President
Williston City Council

ATTEST: Latricia Wright
City Clerk

APPROVED AS TO FORM AND LEGALITY:

Frederick L. Koberlein, Jr.,
City Attorney



CITY OF
WILLISTON
FLORIDA

50 N.W. Main ST. • P.O. Drawer 160 • Williston, Florida 32696-0160
Phone (352) 528-3060 • Fax (352) 528-2877

PO NUMBER: 1452

To: **Thompson Pump**
4620 City Center Dr.
Port Orange, FL. 32119

Date: 10/19/2020

Ship To: City of Williston
50 NW Main St.
Williston, FL. 32696

Shipping Instructions:
25 SW 1 Ave.
Williston, FL. 32696

Quantity:	Description:	Unit Price:	Total Price
1 EA.	Thompson Pump Model 6JSCEE-DDST-2.9 FSA20-EQU18.0-HEAVY EQUIPMENT, ITEM 276	\$39,766.00	\$39,766.00
		TOTAL:	\$39,766.00

INSTRUCTIONS TO VENDOR: Mail all invoices in duplicate, Showing Purchase Order Number, to the Purchasing Department, City of Williston, immediately upon shipment of goods. Show cash discount on all invoices. Please acknowledge ThisPurchase Order shipping date

CITY OF WILLISTON, FLORIDA

Purchasing Agent

The mission of the City of Williston is to offer an efficient affordable and safe place to live, work and play.

Mayor – JERRY ROBINSON / President – JUSTIN HEAD
Vice President – MARGUERITE ROBINSON
Council members -CHARLES GOODMAN – DEBRA JONES – ELIHU ROSS
City Manager –JACKIE GORMAN / City Clerk – LATRICIA WRIGHT



PURCHASE ORDER REQUEST FORM

Date: 10/19/2020	Quote: OSC-TG-279R1
Vendor Name: Thompson Pump	
Address: 4620 City Center Dr.	
City, State, Zip: Port Orange, FL. 32119	
Phone Number: 352-528-3060	Fax Number:

QUANTITY	DESCRIPTION	UNIT PRICE	TOTAL PRICE
1 EA.	Thompson Pump Model 6JSCEE-DDST-2.9	\$39,766.00	\$39,766.00
	C.I.P.		
		TOTAL	\$39,766.00

Fund	Department	Division	Type/Object

CJ ZIMOSKI Department Head Name (Print)	 Department Head Signature
Finance Approval <i>1452</i>	City Manager Approval <i>10/19/2020</i>
Purchase Order Number Assigned:	Date Number Assigned

INSTRUCTIONS
Please print legibly and complete the entire form

- Vendor Name:** The vendor name, complete mailing address, telephone number, and fax number are ALL required. If there is more than one address for this vendor, then indicate the address where the purchase order is to be sent. If the vendor is an individual, the person's legal name must be provided with middle initial, i.e. William E. Smith (not Bill Smith).
- Date:** Date of the request. **Date Required:** Date by which delivery is needed.
- Quantity, Description, Unite, Price & Total Price:** For each item provide quantity, a complete description and the unit price.
- Purchase Order Number:** Assigned by Purchasing Department.
- Required Attachments:**
1. Formal Request for Bid or Formal Request for Quotes and
 2. Original Vendor Quotes or Proposal and
 3. Quote or Bid Tabulation Sheet and
 4. Resolution Approving Bid or Approval of City Manager



**FSA AWARDED
CONTRACT**

fisheriffs.org | 850-877-2166
cpp@fisheriffs.org

Municipal Sales
4620 City Center Dr., Port Orange, FL, USA 32119
(800) 767-7310 • Fax: (386) 761-0362
tguerra@thompsonpump.com

PRICE QUOTE
FSA20-EQU18.0-Heavy Equipment, Item 276

Description	Order Codes	Qty	FSA	Subtotal
6JSC	Vehicle			
Zone:	Central			
Base Price:		1	\$ 38,714.00	\$ 38,714.00
Base Model includes: TPM standard control Panel with start and stop floats, tachometer/hour meter/engine safety shut down), battery charger, spare tire, electric brakes, light package, trailer, and 24 month warranty				
Delete Options:				
Add Options:				
<< Upgrade pump from 6JSC to 6JSC-LHP-10	6JSC-LHP-10	1	\$ 1,052.00	\$ 1,052.00
Final Model: 6JSCEE-DDST-2.9			Total	\$ 39,766.00

* Terms & Conditions *	
• DELIVERY FREIGHT: N/C	
• FOB: PORT ORANGE, FL 32129	
• TERMS: NET 30-DAYS (WITH APPROVED CREDIT)	
• DELIVERY: 14-16 WEEKS OR SOONER AFTER RECEIPT OF A HARD COPY PURCHASE ORDER	
• PLEASE PROVIDE A TAX EXEMPTION CERTIFICATE AT TIME OF ORDER IF APPLICABLE	
• NO PENALTIES OR LIQUIDATED DAMAGES ARE ACCEPTABLE	
• CANCELLATION OF THIS ORDER OR RETURN OF THIS UNIT MAY RESULT IN RE-STOCKING FEES	
• INCLUDES TRAILER WITH 6" ON SUCTION MCAM & DISCHARGE MCAM	

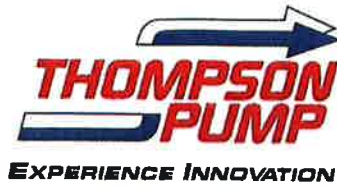

FSA AWARDED
CONTRACT

fisheriffs.org | 850-877-2165
cpp@fisheriffs.org

Municipal Sales
4620 City Center Dr., Port Orange, FL, USA 32119
(800) 767-7310 • Fax: (386) 761-0362
tguerra@thompsonpump.com

PRICE QUOTE
FSA20-EQU18.0-Heavy Equipment, Item 276

Description	Order Codes	Qty	FSA	Subtotal
6JSC	Vehicle			
Zone:	Central			
Base Price:		1	\$ 38,714.00	\$ 38,714.00
Base Model includes: TPM standard control Panel with start and stop floats, tachometer/hour meter/engine safety shut down), battery charger, spare tire, electric brakes, light package, trailer, and 24 month warranty				
Delete Options:				
Add Options:				
<< Upgrade pump from 6JSC to 6JSC-LHP-10	6JSC-LHP-10	1	\$ 1,052.00	\$ 1,052.00
Final Model: 6JSCEE-DDST-2.9			Total	\$ 39,766.00

* Terms & Conditions *
• DELIVERY FREIGHT: N/C
• FOB: PORT ORANGE, FL 32129
• TERMS: NET 30-DAYS (WITH APPROVED CREDIT)
• DELIVERY: 14-16 WEEKS OR SOONER AFTER RECEIPT OF A HARD COPY PURCHASE ORDER
• PLEASE PROVIDE A TAX EXEMPTION CERTIFICATE AT TIME OF ORDER IF APPLICABLE
• NO PENALTIES OR LIQUIDATED DAMAGES ARE ACCEPTABLE
• CANCELLATION OF THIS ORDER OR RETURN OF THIS UNIT MAY RESULT IN RE-STOCKING FEES
• INCLUDES TRAILER WITH 6" ON SUCTION MCAM & DISCHARGE MCAM



**FSA AWARDED
CONTRACT**
flsheriffs.org | 850-877-2165
cpp@flsheriffs.org

Municipal Sales
4620 City Center Dr., Port Orange, FL, USA 32119
(800) 767-7310 • Fax: (386) 761-0362
tguerra@thompsonpump.com

October 16, 2020

Quote # OSC-TG-279r1

City of Williston
Utilities Director
50 NW Main Street
Williston, FL 32696
Attn: CJ Zimoski

Phone: 352-528-3060
Email: cj.zimoski@willistonfl.org

Re: FY2020 Thompson Pump 6JSCEE stock pump

CJ,

Thank you for your interest in Thompson Pump & Manufacturing and the products and the services that we provide. We understand that this pump will be utilized by City of Williston for general water/storm water pumping applications throughout the county.

Per your request, we are providing 2020 Florida Sheriffs Association Contract Package Specification pricing for (1) Thompson Pump Model 6JSCEE-DDST-2.9, a 6" dry prime, solids handling, Final Tier 4 diesel engine powered, open trailer mounted portable Pump. The Thompson 6JSCEE-DDST-2.9 is designed for high flows to 2,400 gpm and heads to 125 feet making it perfect for sewage bypass pumping or general construction dewatering

The net price is derived from our 2020 Florida Sheriffs Association Contract Bid Award # FSA20-EQU18.0-Heavy Equipment, Item 276. This Florida based government contract enables the City of Williston to avoid the hassle and expense of purchasing this pump through the public bid process. The FSA contract basically works like a "piggy back" for our equipment. You can order this unit by simply putting our FSA bid award number on your purchase order. Our FSA contract number is: **FSA20-EQU18.0-Heavy Equipment, Item 276. Please place this contract number on your order.**

Should you require further information or have any questions, please contact me at 407-473-2002 or tguerra@thompsonpump.com.

Sincerely,

Terry Guerra

Terry Guerra
Thompson Pump & Manufacturing Co., Inc. Municipal Sales Representative – Cell: (407) 473-2002,
Email: tguerra@thompsonpump.com

CC: Dave Perry, TPM, Municipal Sales Manager



Experience Innovation

Model: 6" Compressor-Assisted Solids Handling Pump

Name: 6JSCEE

With its heavy-duty cast-iron construction and fast priming capabilities, the Thompson 6JSCEE solids handling end suction centrifugal pump leads the industry in construction, industrial and municipal applications. The Thompson 6JSCEE is designed for moderate flows up to 2,600 gpm and heads up to 150 feet making it perfect for sewage bypass pumping or general construction dewatering.



*Photo shown may not be exact model.

Consult factory for other options including but not limited to skid mounting or sound attenuation.

Pump End Materials	
Pump Casing	Heavy-duty class 30 ductile-iron.
Impeller	Dynamically balanced, non-clogging, enclosed, 65-45-12 ductile iron with rear-equalizing vanes to reduce axial loading and prolong seal and bearing life; diameter 10.1".
Mechanical Seal	Dry-running, grease or oil lubricated with tungsten carbide rotating and silicon carbide stationary seal faces. Single inside mounted, non-pusher type with self-adjusting elastomeric bellows. Other components are 304 stainless steel and Viton.
Head	Rugged, back pull out design, heavy-duty class 30 cast iron with tapered bore design.
Bearings	Heavy-duty grease lubricated to carry both axial and radial loads.
Bearing Frame	Heavy-duty class 30 cast iron.
Shaft	SAE 1144 high quality stress-proof steel with renew-

Technical Specifications

Suction Size	6 in (15.24 cm)	Approximate Dry Weight	4,100 lbs (1,859.73 kg)
Discharge Size	6 in (15.24 cm)	Best Efficiency	75%
Maximum Solids Handling	3 in (7.62 cm)	Maximum Operating Speed	2,200 rpm
Maximum Operating Temperature	200° F (93.33° C)	Maximum Operating Pressure	65 psi (447.71 kPa)

Fuel Tank Options*

Deutz

Integral	62 Gal	24 Hours
Modular (M)	100 Gal	38 Hours
Double-Wall (D)	75 Gal	28 Hours
Modular Large Capacity (X)	150 Gal	57Hours

*Contact factory for fuel tank sizes not listed above.

Thompson Pump and Manufacturing Co., Inc.
4620 City Center Drive, Port Orange, FL 32129 USA
www.thompsonpump.com

Nationwide 800-767-7310 • International +1-386-767-7310
sales@thompsonpump.com

Jun-20

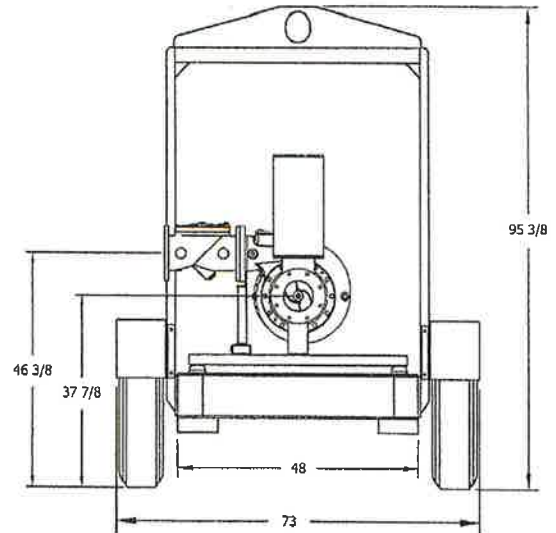
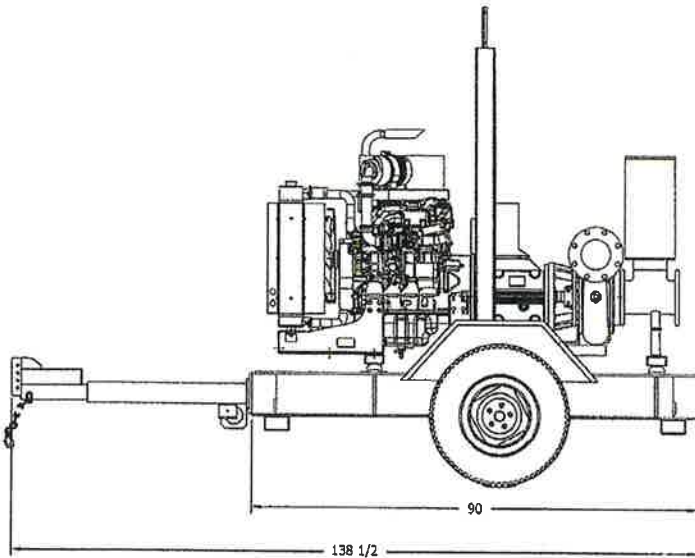
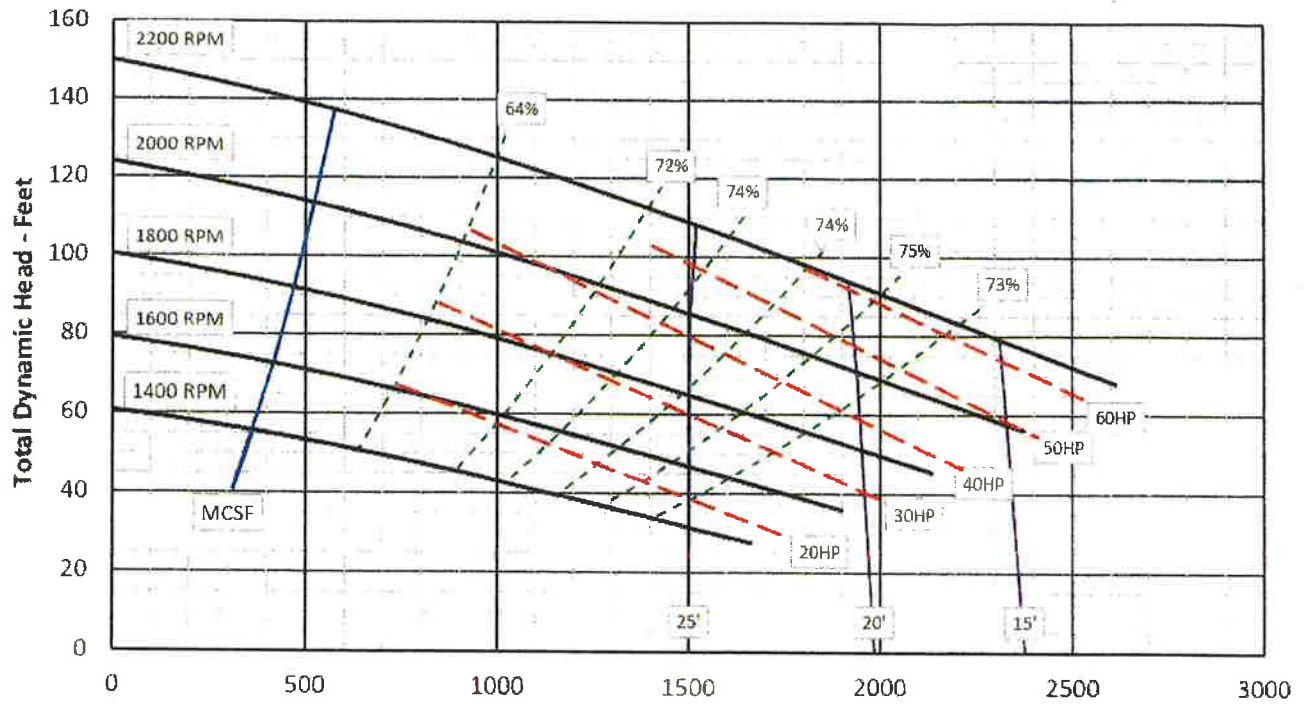

Deutz TD2.9L4— 49 hp @ 2,600 rpm				
Typical Operating Speed	1,800 rpm	Engine Speed	Fuel Economy	Run Time*
Maximum Head	125 ft (45.72 m)	2,000 rpm	0.390 lb/hp-hr	19 hrs
Maximum Flow Capacity	2,400 gpm (590.2 m ³ /hr)	1,800 rpm	0.379 lb-hp-hr	26 hrs
Maximum Fuel Consumption	3.26 gph (16.39 L/hr)	1,600 rpm	0.375 lb-hp-hr	40 hrs

*Engine run times calculated based on a 62 gallon fuel tank.

Specifications and illustrations are subject to revision without notice and without incurring any obligation for previous or subsequent equipment sold. Thompson Pump (ISO 9001:2015) makes no representation regarding the completeness or accuracy of this information and is not liable for any direct or indirect damages arising from or relating to this information or its use. Capacity & Head are shown for comparative purposes. Consult Thompson factory for exact capabilities.

COUNCIL AGENDA ITEM

November 4, 2020

TOPIC: RESOLUTION 2020 - 72 of the City of Williston, Levy County, Florida, approving a proposed final subdivision plat for Cottage Cove North, Phase 3.

REQUESTED BY: Jackie Gorman, City Manager

BACKGROUND / DESCRIPTION:

Cottage Cove North, Phase 3 falls under the description for a Minor Subdivision. This project is located off NW 5th Place and North Main Street. Hoolihan Enterprises, LLC is the owner and Steven McMillan, Surveyor is the Agent.

Cottage Cove North, Phase 3 consists of 4 lots (Lots 9-12); 3 of which fronts NW 5th Place and Lot 9 is a flag lot accessed to the West of Lot 10. All lots meet the minimum size requirement for a R-2 zoning district. Easements have been put in place on the plat to accommodate Electric Utilities, all other utilities will be private.

LEGAL REVIEW:

FISCAL IMPACTS: None

RECOMMENDED ACTION:

City Council approved Final Subdivision Plat for Cottage Cove North, Phase 3, on October 20, 2020, 5-0.

ATTACHMENTS:

Staff Report
Resolution 2020-72

PLANNING COMMISSION ACTION:

_____ **APPROVED**

_____ **DISAPPROVED**

CITY COUNCIL RESOLUTION 2020 - 72

A RESOLUTION OF THE CITY COUNCIL OF THE CITY OF WILLISTON, FLORIDA, APPROVING A PROPOSED FINAL SUBDIVISION PLAT FOR COTTAGE COVE NORTH, PHASE 3.

WHEREAS, a proposed final subdivision plat for Cottage Cove North, Phase 3, located off NW 5th Place and North Main Street, has been filed with the City, and

WHEREAS, the City of Williston Planning and Zoning Commission approved the final subdivision plat on September 29, 2020 and

WHEREAS, the City Council approved the final subdivision plat on October 20, 2020.

NOW, THEREFORE, BE IT RESOLVED BY THE CITY COUNCIL OF THE CITY OF WILLISTON, FLORIDA, AS FOLLOWS:

Section 1. the above recitals are true and accurate and are made part of this resolution.

Section 2. The City Council hereby approves the Final Subdivision Plat for Cottage Cove North, Phase 3.

Section 3. This resolution shall become effective immediately upon adoption.

PASSED AND ADOPTED at a meeting of the City Council this 4th day of November 2020.

CITY OF WILLISTON, FLORIDA

Justin Head, City Council President

ATTEST:

By: _____
Latricia Wright, City Clerk

APPROVED AS TO FORM AND LEGALITY

By: _____
Frederick L. Koberlein, Jr., City
City Attorney

PART OF LOT 2, KAVANAUGH ACRES, REPLAT COTTAGE COVE NORTH PHASE 3 MINOR SUBDIVISION

Lying in Section 31, Township 12 South, Range 19 East,
City of Wilton, County of Levy, State of Florida

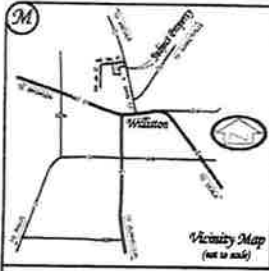

NOT NECESSARY TO BE RECORDED IN PUBLIC RECORDS
UNLESS THE CITY OF WILTON, FLORIDA, HAS ADOPTED BY ORDINANCE
A RESOLUTION TO REQUIRE THE RECORDING OF THIS INSTRUMENT
IN THE PUBLIC RECORDS OF LEVY COUNTY, FLORIDA.

P.O.C.
Point of Commencement
The Point of Commencement is located at the intersection of the centerlines of N.W. 5th Street and N.W. 5th Place, as shown on the plat.

P.O.B.
Point of Beginning
The Point of Beginning is located at the intersection of the centerlines of N.W. 5th Street and N.W. 5th Place, as shown on the plat.



- NOTES:
1. All measurements are taken on an assumed spheroid, North American Datum of 1983, with a mean spherical radius of 6378.137 kilometers, and a semi-major axis of 6378.137 kilometers.
 2. The horizontal angle of 100.000 degrees is a right angle.
 3. At the time of preparation, the roads indicated as public were not in place and were not shown. Such roads are shown as private roads and are not shown by the surveying instrument. In such cases, the City of Wilton is not responsible for maintenance of the roads.

Description: (by surveyor)
A part of Lot 2, Kavanaugh Acres, according to the plat thereof, as recorded in Plat Book 9, Page 43, Public Records of Levy County, Florida lying in Section 31, Township 12 South, Range 19 East, Levy County, Florida, being more particularly described as follows:

Commence at the Northwest corner of Lot 1, said Kavanaugh Acres, lying on the South right-of-way line of N.W. 5th Place and the East right-of-way line of N.W. 5th Street, said point being the Northwest corner of Cottage Cove North Phase 2, according to the plat thereof, as recorded in Plat Book 11, Page 30, Public Records of Levy County, Florida and run thence North 82°58'02"E, along said South right-of-way line, a distance of 448.29 feet to the Northwest corner of Lot 3, Cottage Cove North Phase 2, according to the plat thereof, as recorded in Plat Book 11, Page 30, said Public Records, and the Northwest corner of the herein described parcel. Thence continue North 82°58'02"E, along said South right-of-way line, a distance of 242.00 feet to the West right-of-way line of North Main Street, said point lying on a non-largely curve, variance Southwesterly, having a radius of 1821.88 feet, a West angle of 82°58'02" and a chord bearing and distance of South 24°17'12"E and 162.28 feet. Thence Southwesterly, along said curve and along said curve angle of 82°58'02" and a chord bearing and distance of South 24°17'12"E and 162.28 feet. Thence South 14°51'00"W, a distance of 212.00 feet to the north line of Lot 3, Cottage Cove, according to the plat thereof, as recorded in Plat Book 11, Page 30, said Public Records; thence North 82°51'31"W, along the said North line and its Westerly extension, a distance of 206.83 feet to the Southeast corner of Lot 7, said Cottage Cove North Phase 2; thence North 07°10'10"W, a distance of 312.80 feet to the said Point-of-Beginning.

Containing 1.844 Acres, more or less.

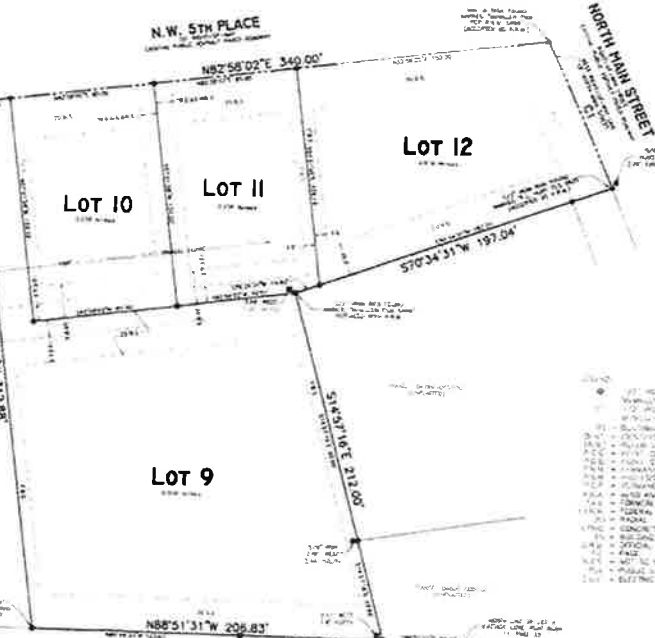

- 1. 100' x 100' x 100'
- 2. 100' x 100' x 100'
- 3. 100' x 100' x 100'
- 4. 100' x 100' x 100'
- 5. 100' x 100' x 100'
- 6. 100' x 100' x 100'
- 7. 100' x 100' x 100'
- 8. 100' x 100' x 100'
- 9. 100' x 100' x 100'
- 10. 100' x 100' x 100'
- 11. 100' x 100' x 100'
- 12. 100' x 100' x 100'
- 13. 100' x 100' x 100'
- 14. 100' x 100' x 100'
- 15. 100' x 100' x 100'
- 16. 100' x 100' x 100'
- 17. 100' x 100' x 100'
- 18. 100' x 100' x 100'
- 19. 100' x 100' x 100'
- 20. 100' x 100' x 100'

Plat Book , Page
Sheet One of One

Owner's Certification and Acknowledgment
I, the undersigned, being the owner of the above described premises, do hereby certify that the contents of this plat are true and correct, and that the same have been prepared by a duly qualified and licensed surveyor, and that the same have been recorded in the Public Records of Levy County, Florida, in accordance with the provisions of Chapter 173, Florida Statutes, and that the same are a true and correct copy of the original plat on file in the office of the Surveyor General of Florida.

Acknowledgment: I, the undersigned, being the owner of the above described premises, do hereby acknowledge that the contents of this plat are true and correct, and that the same have been prepared by a duly qualified and licensed surveyor, and that the same have been recorded in the Public Records of Levy County, Florida, in accordance with the provisions of Chapter 173, Florida Statutes, and that the same are a true and correct copy of the original plat on file in the office of the Surveyor General of Florida.

Surveyor's Certificate
I, the undersigned, being a duly qualified and licensed surveyor, do hereby certify that the contents of this plat are true and correct, and that the same have been prepared by me, or by a duly qualified and licensed assistant surveyor, and that the same have been recorded in the Public Records of Levy County, Florida, in accordance with the provisions of Chapter 173, Florida Statutes, and that the same are a true and correct copy of the original plat on file in the office of the Surveyor General of Florida.

Certificate of City Attorney
I, the undersigned, being the City Attorney of the City of Wilton, Florida, do hereby certify that the contents of this plat are true and correct, and that the same have been prepared by a duly qualified and licensed surveyor, and that the same have been recorded in the Public Records of Levy County, Florida, in accordance with the provisions of Chapter 173, Florida Statutes, and that the same are a true and correct copy of the original plat on file in the office of the Surveyor General of Florida.

Certificate of Approval and Acceptance of Dedication
I, the undersigned, being the City Engineer of the City of Wilton, Florida, do hereby certify that the contents of this plat are true and correct, and that the same have been prepared by a duly qualified and licensed surveyor, and that the same have been recorded in the Public Records of Levy County, Florida, in accordance with the provisions of Chapter 173, Florida Statutes, and that the same are a true and correct copy of the original plat on file in the office of the Surveyor General of Florida.

City Engineer _____
City Clerk _____

Survey Requirements
This plat is subject to the provisions of Chapter 173, Florida Statutes, and the provisions of the rules and regulations of the Surveyor General of Florida, and the provisions of the rules and regulations of the City of Wilton, Florida.

Clerk of the Court
I, the undersigned, being the Clerk of the Court of the County of Levy, Florida, do hereby certify that the contents of this plat are true and correct, and that the same have been prepared by a duly qualified and licensed surveyor, and that the same have been recorded in the Public Records of Levy County, Florida, in accordance with the provisions of Chapter 173, Florida Statutes, and that the same are a true and correct copy of the original plat on file in the office of the Surveyor General of Florida.

NOTICE: This plat is subject to the provisions of Chapter 173, Florida Statutes, and the provisions of the rules and regulations of the Surveyor General of Florida, and the provisions of the rules and regulations of the City of Wilton, Florida. This plat is subject to the provisions of Chapter 173, Florida Statutes, and the provisions of the rules and regulations of the Surveyor General of Florida, and the provisions of the rules and regulations of the City of Wilton, Florida.

2
Revised

Date: November 4, 2020

COUNCIL AGENDA ITEM

TOPIC: RESOLUTION 2020-73 - A resolution of the city of Williston, Levy County, Florida, granting with appropriate conditions and safeguards, a special exception per ordinance 673 of the city of Williston Code of Ordinances; providing for a special exception to the permitted uses within residential zoning to allow horses for non-commercial purposes on parcels of three (3) acres or more (but less than eight (8) acres) within the corporate limits of the city of Williston, Florida; and providing an effective date.; and providing an effective date.

PREPARED BY: Jackie Gorman, City Manager

BACKGROUND / DESCRIPTION: Marc & Melanie Nussel are the applicants and owners of the subject property located at 270 NE 6th Blvd. The Applicant requested a special exception to allow horses on their residential property.

LEGAL REVIEW: Yes

FISCAL IMPACTS: No

RECOMMENDED ACTION:

Planning Commission recommended APPROVAL 4-0 on October 5, 2020 with the contingency that the applicant prove to City Council they have the required acreage of open and improved pasture.

City Council Approved Special Exception SE-2020-03, 5-0, on October 20, 2020.

ATTACHMENTS: Yes

Staff Report
Resolution 2020-73

COMMISSION ACTION:

_____ APPROVED _____ DISAPPROVED

CITY COUNCIL RESOLUTION 2020 - 73

A RESOLUTION OF THE CITY COUNCIL OF THE CITY OF WILLISTON, FLORIDA, GRANTING WITH APPROPRIATE CONDITIONS AND SAFEGUARDS, A SPECIAL EXCEPTION PER ORDINANCE 673 OF THE CITY OF WILLISTON CODE OF ORDINANCES; PROVIDING FOR A SPECIAL EXCEPTION TO THE PERMITTED USES WITHIN RESIDENTIAL ZONING TO ALLOW HORSES FOR NON-COMMERCIAL PURPOSES ON PARCELS OF THREE (3) ACRES OR MORE (BUT LESS THAN EIGHT (8)) ACRES WITHIN THE CORPORATE LIMITS OF THE CITY OF WILLISTON, FLORIDA; AND PROVIDING AN EFFECTIVE DATE.

WHEREAS, Special Exception SE 2020-3, Marc & Melanie Nussel applied for a special exception, per Article VI, to allow horses for non-commercial purposes on parcels of 3 acres or more (but less than eight) acres at a residential property located at:

270 NE 6th Blvd., 31-12-19 TRACT IN SE 1/4 OF NE 1/4 OR BOOK 232 PAGE 195 & OR BOOK 1484 PAGE 114 & OR BOOK 1425 PAGE 184 - 3.640 Acres, Parcel ID 0408-002-00

WHEREAS, the City of Williston Land Development Regulations, as amended, hereinafter referred to as the Land Development Regulations, empowers the City Council of the City of Williston, Florida, hereinafter referred to as the City Council, to grant, to grant with appropriate conditions and safeguards or to deny Special Exceptions as authorized under Section 60-375 (1) of the Land Development Regulations; and

WHEREAS, the City of Williston Planning and Zoning Commission approved the Special Exception SE 2020-3 on October 5, 2020; and

WHEREAS, the City Council approved the Special Exception SE 2020-3 on October 20, 2020.

NOW, THEREFORE, BE IT RESOLVED BY THE CITY COUNCIL OF THE CITY OF WILLISTON, FLORIDA, AS FOLLOWS:

Section 1. The foregoing "WHEREAS" clauses are hereby ratified and confirmed as being true and correct and are incorporated herein by this reference.

Section 2. The City Council hereby approves Special Exception SE 2020-3.

Section 3. This resolution shall become effective immediately upon adoption.

PASSED AND ADOPTED at a meeting of the City Council this 4th day of November 2020.

CITY OF WILLISTON, FLORIDA

Justin Head, City Council President

ATTEST:

By: _____
Latricia Wright, City Clerk

APPROVED AS TO FORM AND LEGALITY:

By: _____
Frederick L. Koberlein, Jr.,
City Attorney

Date: 11/04/2020

COUNCIL AGENDA ITEM

DISCUSSION: Request to extend the hours at Cornelius Williams Park on November 14, 2020 until 10:30PM to allow Javier Castro on behalf of Iglesia Casa del Alfarero to hold a Church Service/Concert on and around the Basketball Courts.

REQUESTED BY: CJ Zimoski

PREPARED BY: CJ Zimoski

BACKGROUND / DESCRIPTION: It is the desire of Javier Castro, to hold a Church Service/Concert in Cornelius Williams Park. The standard Park hours are "Open from sunrise until sunset". Javier is requesting an extension until 10:30 PM and does not require additional Police or Emergency Service presence.

LEGAL REVIEW: Sent to the City Attorney

FISCAL IMPACTS: N/A

RECOMMENDED ACTION: Staff recommends approval of this onetime event.

ATTACHMENTS:

CONTRACT RESOLUTION MAP
 LEASE OTHER DOCUMENTS

CONSULTANT OR PARTY TO ACTION HAS BEEN NOTIFIED

COUNCIL ACTION:

APPROVED
 DISAPPROVED

Date: November 4, 2020

COUNCIL AGENDA ITEM

TOPIC: Lien reduction for property located at 415 SE 4th Drive – Carol Chico (formerly owned by Falisi) – Request for Extension

REQUESTED BY: CHICO CAROL

PREPARED BY: Jackie Gorman, City Manager

BACKGROUND / DESCRIPTION:

On September 22, 2020, the City Council agreed to reduce several liens provided the payment was made within 30 days. Carol Chico was one of the liens on the list. Council agreed to reduce the lien from \$44,400 to \$2,545.51.

Ms. Chico currently lives in Puerto Rico and until recently was represented by her father Carlo Chico. Attached you will find correspondence from the City to Ms. Chico and her response basically requesting time to sort through this issue since she is trying to obtain a Power of Attorney so her father can act on her behalf. She is also requesting a payment plan for the lien.

LEGAL REVIEW: Yes

FISCAL IMPACTS: N/A

RECOMMENDED ACTION:

To extend the time limit for payment of the lien since the property is now in compliance along with approval to enter into a Promissory Note for payment.

ATTACHMENTS: (3) letters of correspondence

COMMISSION ACTION:

_____ **APPROVED**

_____ **DISAPPROVED**



CITY OF
WILLISTON
FLORIDA

50 N.W. Main ST. • P.O. Drawer 160 • Williston, Florida 32696-0160
Phone (352) 528-3060 • Fax (352) 528-2677

October 7, 2020

HAND DELIVERED

Carol Chico
415 SE 4th Drive
Williston, FL 32696

RE: CV18-13 - Lien reduction for property located at 415 SE 4th Drive, Williston, FL

Ms. Chico,

This letter is a follow-up from a telephone conversation we had concerning the referenced property. On September 22, 2020, the City Council agreed to reduce the lien on your family's property from \$44,400 (as of 9/22/2020) to \$2,545.51 and they agreed to give 30 days for payment. Afterwards, this lien reduction will go away, the fines will continue to accrue, and the City Attorney will proceed with the foreclosure.

If you would like to request additional time to pay this lien, please be prepared to come before the City Council with your request at the next meeting which is October 20, 2020 6:00 pm. Be sure to contact the City Clerk to be placed on the Agenda.

Please do not ignore this opportunity and let us know if we can be of assistance.

Sincerely,

Laura Jones
Assistant Planner

cc: Chico Carol, Urbanizacion Altura De San Pedro, Calle San Lucas 148, Fajardo, PR
00738
Jackie Gorman, City Manager

October 15, 2020

Attn: Jackie Gorman, City Manager
City of Williston
50 NW Main St
Williston, Florida 32696

RE: CV18-13 – Lien reduction for property located at 415 SE 4th Drive, Williston, FL

My father and I received the follow up letter dated October 7, 2020 on October 13, 2020.

Please don't think that I have forgotten about the power of attorney. Things here in the island take for ever, it is under review by the Supreme Tribunal. Once approved, I will forward to my father and to you.

Until the power of attorney is finalized, I do not wish to have my father speak for me. I do not want the City Commission think that I am pulling their leg.

All I wanted was a just resolve to the matter, your lien reduction is reasonable to a point. I will like a breakdown of how the Commission came to that number.

Once we are in accordance, I am able to make a payment plan, pay for my permit and move to the home.

I will then take the matter to Small Claims against the prior owners, and look forward to residing in a town that practices its Constitutional duties to everyone.

Please ask the Commission on my behalf for the fee breakdown, and if we need another hearing, I am hoping for the power of attorney to be finalized by then.

Thank You

Carol Chico

A handwritten signature in black ink, appearing to read "Carol Chico". The signature is written in a cursive, flowing style with large loops and a long tail on the final letter.



CITY OF
WILLISTON
FLORIDA

50 N.W. Main ST. • P.O. Drawer 160 • Williston, Florida 32898-0160
Phone (352) 528-3060 • Fax (352) 528-2877

October 16, 2020

Carol Chico
415 SE 4th Drive
Williston, FL 32696

RE: CV18-13 - Lien reduction for property located at 415 SE 4th Drive, Williston, FL

Ms. Chico,

This letter is a response to a letter received via email on October 15, 2020. On September 22, 2020, the City Council agreed to reduce the lien on your property from \$44,400 (as of 9/22/2020) to \$2,545.51 and they agreed to give 30 days for payment.

On September 22, 2020 City Council reduced the lien amount to 5% plus administrative fees. Administrative fees were \$325.51 which included \$250 in prosecution fees as noted in the lien documents, recording fees, and legal fees.

If you would like to request additional time to pay this lien, please contact us before October 22, 2020.

Sincerely,

Laura Jones
Assistant Planner

cc: Chico Carol, Urbanizacion Altura De San Pedro, Calle San Lucas 148, Fajardo, PR
00738
Jackie Gorman, City Manager

Date: November 4, 2020

COUNCIL AGENDA ITEM

TOPIC: Resolution 2020-69. A Resolution of the City Council of the City of Williston, Florida, approving the 2021 General Municipal Election Dates and Process and Establishing an Effective Date.

REQUESTED BY: CITY CLERK

PREPARED BY: Atty. Fred Koberlein, Jr.

BACKGROUND / DESCRIPTION: The Charter of the City of Williston requires biennial elections to fill expired terms of the City Council and Mayor per the established election cycle.

LEGAL REVIEW: Attorney Fred Koberlein, Jr.

FISCAL IMPACTS:

RECOMMENDED ACTION: Approve

ATTACHMENTS: Resolution 2020-69

COMMISSION ACTION:

_____ APPROVED

_____ DISAPPROVED

CITY COUNCIL RESOLUTION NUMBER 2020-69

A RESOLUTION OF THE CITY COUNCIL OF THE CITY OF WILLISTON, FLORIDA, APPROVING THE 2021 GENERAL MUNICIPAL ELECTION DATES AND PROCESS AND ESTABLISHING AN EFFECTIVE DATE.

WHEREAS, the Charter of the City of Williston requires biennial elections to fill expired terms of the City Council and Mayor per the established election cycle; and

WHEREAS, the City of Williston is bound to conduct the election process as required by Florida Statute.

NOW, THEREFORE, BE IT RESOLVED BY THE CITY COUNCIL OF THE CITY OF WILLISTON, FLORIDA, AS FOLLOWS:

Section 1. The above recitals are true and accurate and are made a part of this resolution.

Section 2. The City of Williston Municipal election date is established as Tuesday, March 2, 2021, to fill the following seats: Group A, Group B, Group C, and Group D.

Section 3. If any provision or portion of this resolution is declared by any court of competent jurisdiction to be void, unconstitutional, or unenforceable, then all remaining provisions and portions of this resolution shall remain in full force and effect.

[Remainder of this page left blank intentionally.]

Section 4. This resolution shall become effective immediately upon passage and adoption.

PASSED AND ADOPTED by the City Council on the ____ day of November 2020.

CITY OF WILLISTON, FLORIDA

By: _____
Justin Head,
City Council President

ATTEST:

APPROVED AS TO FORM AND
LEGALITY:

By: _____
Latricia Wright, City Clerk

By: _____
Frederick L. Koberlein, Jr.,
City Attorney

Date: November 4, 2020

COUNCIL AGENDA ITEM

TOPIC: Resolution 2020-70: A Resolution of the City Council of the City of Williston, Florida, appointing the Canvassing Board for the 2021 General Municipal Elections and Establishing an Effective Date.

REQUESTED BY: CITY CLERK

PREPARED BY: Atty. Fred Koberlein, Jr.

BACKGROUND / DESCRIPTION: Designating a Canvassing Board to canvass the votes in accordance with the City Charter and Florida Statue.

LEGAL REVIEW: Attorney Fred Koberlein, Jr.

FISCAL IMPACTS:

RECOMMENDED ACTION: Approve

ATTACHMENTS: Resolution 2020-70

COMMISSION ACTION:

APPROVED

DISAPPROVED

CITY COUNCIL RESOLUTION NUMBER 2020-70

A RESOLUTION OF THE CITY COUNCIL OF THE CITY OF WILLISTON, FLORIDA, APPOINTING THE CANVASSING BOARD FOR THE 2021 GENERAL MUNICIPAL ELECTIONS AND ESTABLISHING AN EFFECTIVE DATE.

WHEREAS, the Charter of the City of Williston requires biennial elections to fill expired terms of the City Council and Mayor pursuant to the established election cycle; and

WHEREAS, the City of Williston is required to designate a Canvassing Board to canvass the votes in accordance with the City Charter and Florida Statutes.

NOW, THEREFORE, BE IT RESOLVED BY THE CITY COUNCIL OF THE CITY OF WILLISTON, FLORIDA, AS FOLLOWS:

Section 1. The above recitals are true and accurate and are made a part of this resolution.

Section 2. This Resolution approves the prescribed Canvassing Board consisting of the Williston City Manager, the Williston Chief of Police, and the Williston Representative from the Levy County Board of County Commissioners; in addition to the designated alternate member Mr. Reggie Williams.

Section 3. If any provision or portion of this resolution is declared by any court of competent jurisdiction to be void, unconstitutional, or unenforceable, then all remaining provisions and portions of this resolution shall remain in full force and effect.

[Remainder of this page left blank intentionally.]

Section 4. This resolution shall become effective immediately upon passage and adoption.

PASSED AND ADOPTED by the City Council on the ____ day of November 2020.

CITY OF WILLISTON, FLORIDA

By: _____
Justin Head,
City Council President

ATTEST:

APPROVED AS TO FORM AND
LEGALITY:

By: _____
Latricia Wright, City Clerk

By: _____
Frederick L. Koberlein, Jr.,
City Attorney

Date: November 4, 2020

COUNCIL AGENDA ITEM

TOPIC: Continuing Economic Development Services

PREPARED BY: Jackie Gorman, City Manager

BACKGROUND / DESCRIPTION:

The City receives requests on a regular basis from the Nature Coast Economic Development Council for information on available space for prospective businesses. Lynn Patterson, PhD, with Three Points Planning, LLC has been working with the City on their Economic Development initiatives and we have requested that Dr. Patterson continue working with staff and assist us with preparing information and providing expert guidance and facilitation on an as-needed basis.

LEGAL REVIEW: Yes

FISCAL IMPACTS: Yes, funds are available and budgeted in Community Development up to \$6,000.

RECOMMENDED ACTION:

Staff recommends approval of the continuing service agreement with Three Points Planning.

ATTACHMENTS: Continuing Economic Development Agreement

COMMISSION ACTION:

_____ **APPROVED**

_____ **DISAPPROVED**

October 19, 2020

Jackie Gorman
City Manager
50 NW Main St
Williston, FL 32696



RE: Continuing Economic Development Services

Dear Ms. Gorman:

As a follow up to our meeting regarding the City's need for economic development consulting for economic development prospects, Three Points Planning believes we can provide ongoing expert guidance and facilitation between the private, public, and quasi-public sectors. Three Points Planning has the economic development and local planning expertise, particularly in smaller communities, to successfully navigate these sectors. As an economic development consultant, Three Points Planning's role will be to identify and secure regional, state, and federal funding and development incentives, coordinate with local and state agencies for transportation, utilities, and workforce development needs, and finalize applications and other documentation for receipt of state and federal incentives and funding assistance. Three Points Planning is pleased to offer the following services:

Scope of Services

Phase 1

Task 1 – Create an informational package for prospects. With information provided by the prospect, the City, and other entities, this package will describe the competitive advantages locating in Williston has to offer. The package will also include an overview of potential resources from the City, region, and State (note, these are not firm commitments).

Task 2 – Identify and secure resources for the Project. Three Points Planning will engage and meet with partners such as the Florida Department of Economic Opportunity (incl REDI), Enterprise Florida, Florida Aviation, Florida DOT, the Florida Chamber of Commerce, the Nature Coast Business Development Council, the North Central Florida Regional Planning Council, the Williston Chamber of Commerce, the US Economic Development Administration, the Federal Aviation Administration, the US Department of Agriculture, and other agencies. These organizations, together, can provide resources for the viability of projects. An MOU outlining the commitments from the organizations and will be presented to the Project team.

Phase 2

Task 1 - Coordinate ongoing needs including, identification of and application for funding improvements.

Task 2 - Management of state and federal resources presented in the MOU.

Task 3 - Facilitation and creation of workforce development programs with workforce development organizations and establishment of partnerships with both the technical colleges and regional universities to create a strong labor supply.

Task 4 – Identification and recruitment of housing developers to the expected 300+ employees,

Task 5 – Finalization of applications and other documentation for receipt of state and federal incentives and funding assistance.

Task 6 – Other tasks related to the project as assigned by the City of Williston.

Fees

Phase 1 – \$115 per hour plus travel, total not to exceed \$10,000 without prior approval of the City of Williston’s City Manager.

Phase 2 - \$115 per hour plus travel.

Thank you for the continued opportunity to serve the City of Williston. We are very excited about Williston’s future.

Sincerely,



Lynn M. Patterson, PhD
Principal, Three Points Planning, LLC

Services Approved by:

On behalf of the City of Williston

Date